



International Journal of Multidisciplinary Research in Science, Engineering and Technology

(A Monthly, Peer Reviewed, Refereed, Scholarly Indexed, Open Access Journal)



Impact Factor: 9.864

Volume 9, Issue 5, May 2026



International Journal of Multidisciplinary Research in Science, Engineering and Technology (IJMRSET)

(A Monthly, Peer Reviewed, Refereed, Scholarly Indexed, Open Access Journal)

Neuro-Fuzzy Based Optimization of RV Multilevel Inverter

Dr. B. Kandavel

Asst. Professor, Dept. of EEE, Sri Chandrasekharendra Saraswathi Viswa Maha Vidyalaya, Kanchipuram, India

ABSTRACT: This paper presents an outline of another 15-level staggered inverter geography named switching voltage (RV) for solar powered inverters. Hence, there is no requirement for all switches to work in high recurrence which prompts easier and more solid control of the inverter. This paper portrays the overall MLI schematic. An overall strategy for staggered balance stage attitude (PD) SPWM is used to drive the inverter and can be reached out to quite a few voltage levels. This type is extremely powerful and proficient for working on the nature of the inverter yield voltage. Correlation is done with regards to Total Harmonic Twisting (THD) in yield load voltage, dynamic Power and receptive Power. Better THD alongside bigger dynamic and receptive powers delivered in second plan as looks at to a specific phases of the primary plan. The reproduction is finished by MATLAB-SIMULINK programming and equipment plan of a 7-level inverter will be finished utilizing PIC-Micro-Controller. The outcomes approves the introduced plan.

KEYWORDS: SPWM, Multi Level Inverter(MLI), PIC Controller, THD.

I. INTRODUCTION

Power Electronics inverters are becoming famous for different modern drive applications. In later year, inverter have been become need for some executions, for example, engine controlling and power framework [1].

Rising fuel costs, expanding worries for worldwide environmental change and a developing overall interest for power has prompted worldwide exertion towards expanding utilization of environmentally friendly power sources, for example, sunlight based, wind, biomass and so forth. If there should be an occurrence of sun powered PV the energy is outfit in dc structure. This dc power is changed over into ac structure and afterward took care of to the framework or utilized in disengaged load. Different techniques are accessible for dc to ac change. Staggered Inverters have acquired prevalence as of late. The power quality gets progressively better with the no. of levels in the result wave [2]

In this way, a staggered inverter (MLI) utilizes the force of semiconductor gadget sources to incorporate the flight of stairs waveform close to a sine waveform. The staggered inverter is the most ideal choice for most of power creation in a SPV framework. The conventional 2-level inverters face high exchanging voltage stress, less effectiveness and low power quality, as expressed in [3,4]. There are many sorts of inverter, including the unbiased clipped, flying capacitor, fell H-span MLI has been accounted for [5-6]. The significant challenges connected with MLI are the more noteworthy number of force switches and trouble in its plan. In MLI, restricting the quantity of switches has achieved significant significance [7]. Restricting the quantity of force switches decreases the trouble and upgrades the presentation of MLI [8].

The main geographies like diode-cinched inverter (impartial point braced), capacitor-clipped (flying capacitor), and fell multicell with independent dc sources are presents here. Most pertinent control and tweak techniques created for this group of converters like Multilevel sinusoidal heartbeat width balance, staggered particular consonant end, and space-vector adjustment [9]

The proposed models produce generated voltages with low THD values as well as produces the required distortion or loss parts on the result voltage. The result voltage as well as the expected explicit music constrained by points. With the necessary distortions parts, the proposed inverter structure is simulated for different variables. Proposed inverter structure acknowledged simulation results and THD data of the result voltage waves [10].



International Journal of Multidisciplinary Research in Science, Engineering and Technology (IJMRSET)

(A Monthly, Peer Reviewed, Refereed, Scholarly Indexed, Open Access Journal)

II. ISSUE STATEMENT

Probably the most concerning issue in the power quality angles is the consonant substance in the electrical framework. Music are the twisting of the typical electrical flow waveform, for the most part sent by non direct loads. Illustration of nonlinear burdens exchanged mode power supplies, variable speed engines and drives, printers, and so on.

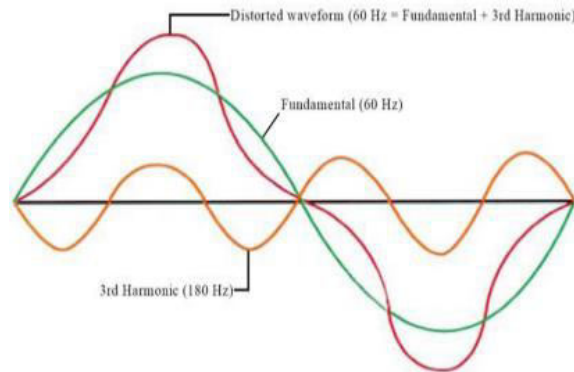

Figure 1: Harmonics in electrical waveforms

Harmonics related issues damages the system effectiveness. As the quantity of harmonics delivering loads have expanded in the new year, it has become important to address their impact during expansion or changes to an establishment. Harmonics flows can essentially affect the electrical conveyance framework and the offices they feed. Distortion goes once again into the power source and can influence other gear associated with something very similar source. By and large harmonics are separated into two types: 1.voltage harmonics 2. Current harmonics.

A. Cascaded H Bridge Inverter

Customary fell staggered inverter is one of the main geographies in the group of staggered and multi-level inverters. The course cascaded permits the utilization of a few levels of DC voltages to combine an ideal AC voltage. The DC levels are viewed as identical since every one of them are energy units or photovoltaic, batteries, and so on. H-Bridge Inverter comprises of four switches, a dc source and a load (Isolated or Grid) across the two arm of H-Bridge. Each switch conducts for a time of 180° . The gate input beats for corner to corner switches are identical.

DC-AC INVERTER:

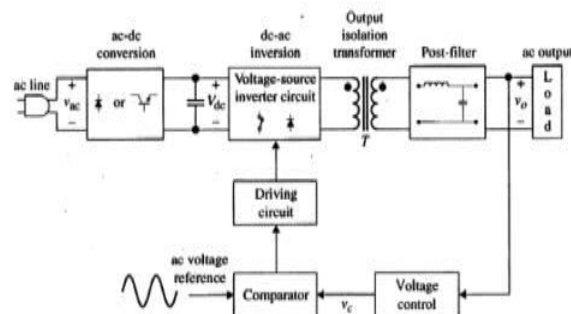

Figure 2: Power Electronic Circuit with DC-AC Inverter.

The distortion can be available in any framework where inverters are utilized. The main point of utilizing an inverter is to create an AC output from the dc source. Hypothetically the result voltage waveform is supposed to be sinusoidal, however in real time process there is most certainly going to be distortion because of harmonics present in the framework which results into distorted output waveforms. Accordingly, inverters are utilized in a framework to create output waveforms which are absolutely sinusoidal and loss free.



International Journal of Multidisciplinary Research in Science, Engineering and Technology (IJMRSET)

(A Monthly, Peer Reviewed, Refereed, Scholarly Indexed, Open Access Journal)

III. EXISTING SYSTEM

As execution of diodes and capacitors is there in other Multi-level Inverters (DCMLI and FCMLI), the voltage drops and the utilization of capacitors increments. Assuming switches are more the PWM Complexity increments, there by expanding the expense and the proficiency likewise the expense and the proficiency likewise diminishes. Even Cascaded MLI must be worked for 28 switches $[S=2(m-1)]$.

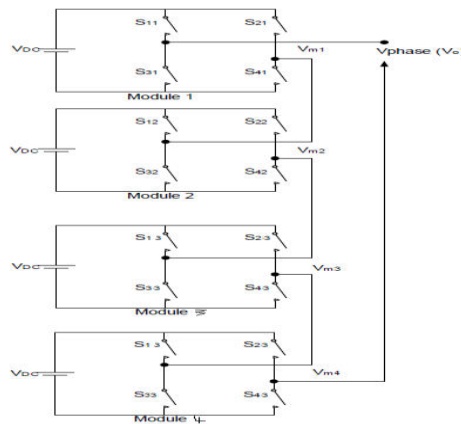

Figure 3: Existing system model without RV

In this system it produce the THD level of 3.87%

IV. PROPOSED SYSTEM

In regular ML inverters, the power semiconductor switches are joined to deliver a high-recurrence waveform in positive and negative polarities. Nonetheless, there is compelling reason need to use every one of the switches for producing bipolar levels. This thought has been tried by the new geography. This topology is a mixture staggered topology what isolates the result voltage into two sections. One section is named level generation part and is answerable for level producing in positive polarity.

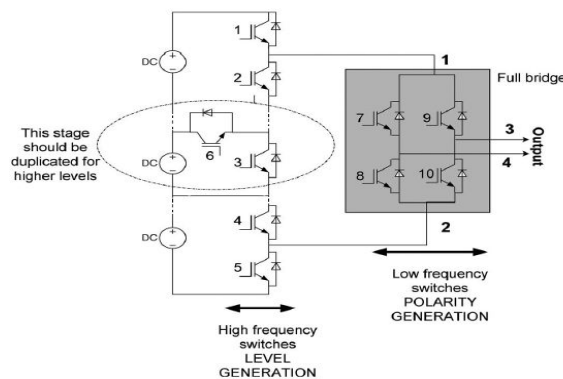

Figure 4: Proposed system model with RV

This part requires high-recurrence switches to produce the expected levels. The switches in this part ought to have high-exchanging recurrence ability. The other part is called polarity generation part and is liable for producing the polarity of the result voltage, which is the low-recurrence part working at line recurrence. The geography joins the two sections (high recurrence and low recurrence) to produce the ML voltage output. To create a total ML output, the positive levels are produced by the high-recurrence part (level age), and afterward, this part is taken care of to a full-bridge inverter



International Journal of Multidisciplinary Research in Science, Engineering and Technology (IJMRSET)

(A Monthly, Peer Reviewed, Refereed, Scholarly Indexed, Open Access Journal)

(polarity generation), which will produce the expected polarity for the result. This will kill a considerable lot of the semiconductor switches which were capable to produce the result voltage levels in positive and negative polarities. This paper presents an outline of another staggered inverter geography named as turning around voltage (RV) for sunlight based inverters. This geography requires less number of parts contrasted with regular geographies. It is additionally more productive since the inverter has a part which works the exchanging power gadgets at line recurrence. Consequently, there is no requirement for all changes to work in high recurrence which prompts more straightforward and more dependable control of the inverter.

V. COMPARISON

The objective of the Neuro-Fuzzy controller is to optimize the switching angles and modulation index of the RV-based multilevel inverter to minimize Total Harmonic Distortion (THD), improve output voltage quality, and enhance power performance. The current paper uses APOD/SPWM techniques for harmonic reduction

Parameter	RV Inverter	Neuro-Fuzzy Optimized RV
THD	0.37–0.54%	Lower
Output Voltage Quality	Good	Better
Dynamic Response	Moderate	Faster
Switching Optimization	Fixed	Adaptive
Power Quality	High	Very High

The THD in yield voltage got in second plan is 0.39% while for fell H-Bridge inverter the base THD found upto 5 level is 14.99%. This shows that if the switches of the converter in first plan (Cascaded H-Bridge) is 18 or less, the THD will be more for example the power quality will be poor as contrast with second plan. Additionally the switches utilized and the result level in first plan having 15 level without RV separately. While the switches utilized and output level in second plan are 15 level with RV separately.

This paper shows just the examination of two plans without the utilization of RV. The THD acquired in output load voltage may generally be less than the 5% by involving method in the two plans. In first plan, for 15 level inverter converter, the THD in voltage is viewed as 3.6% without the RV and for the second plan the THD is 0.37% with RV. Be that as it may, the expense of this plan turns out to be extremely enormous as contrast with second plan because of huge no. of switches utilized.

VI. OUTPUT SNAPS

For the instance of single unit and upto cascaded association of 15 units, the subsequent plan supposedly offers less THD.

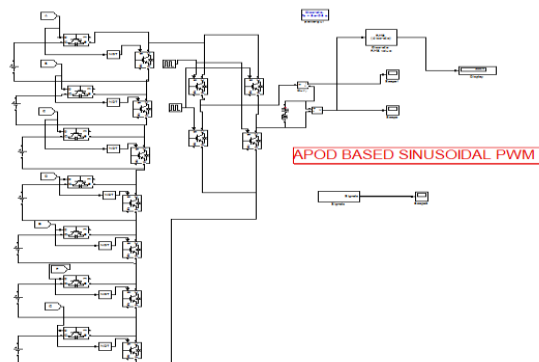

The variation of THD with no. of stages is shown in Figure 5.



International Journal of Multidisciplinary Research in Science, Engineering and Technology (IJMRSET)

(A Monthly, Peer Reviewed, Refereed, Scholarly Indexed, Open Access Journal)

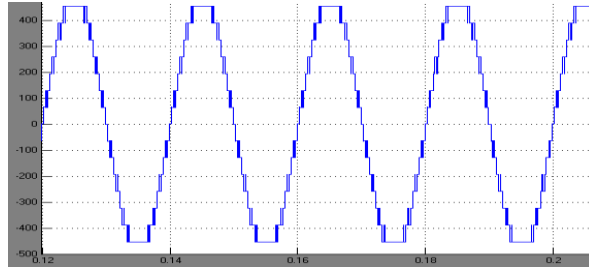
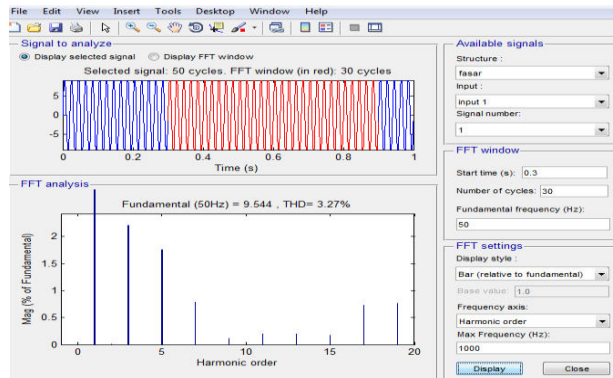
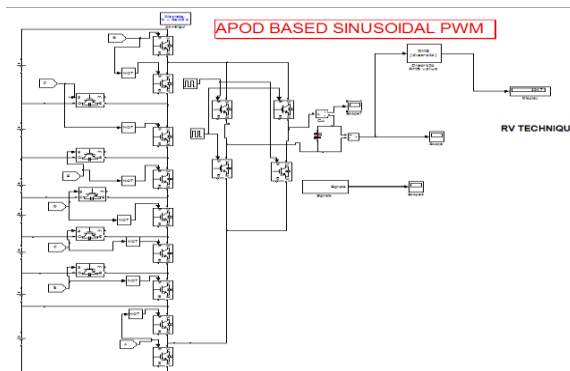

Fig .6 Output from the APOD based pulse width modulation technique with 15 level of waveform without the RV



The figure. 7 THD for first model without the RV



The figure. 8 proposed model with APOD pulse width modulation technique with RV system

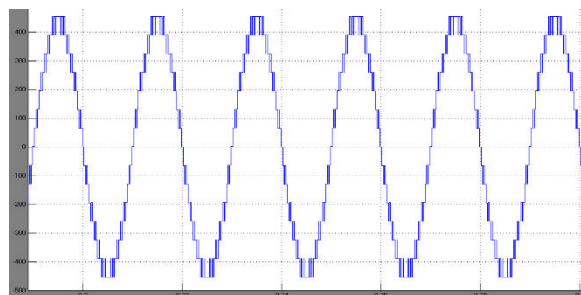

Fig.9 Output wave for 18 switch MLI inverter output voltage with 15 level of waveform



International Journal of Multidisciplinary Research in Science, Engineering and Technology (IJMRSET)

(A Monthly, Peer Reviewed, Refereed, Scholarly Indexed, Open Access Journal)

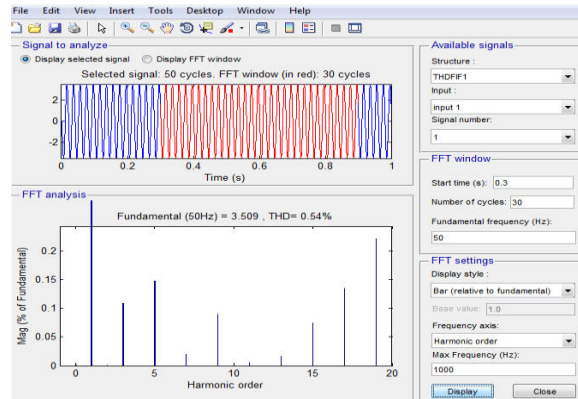

Fig.10 Assuming that the stages are expanded past 5, the THD will be better for second plan with RV.

- 15-level (18-switch) asymmetrical Level Inverter- 3.27%
- 15-level (18-switch) asymmetrical Level Inverter (RV TECHNIQUE)- 0.54%

By simulation, the calculation is done and it is proved : By operating more levels, THD can be decreased which forms the ultimate principle of multi-level inverters.

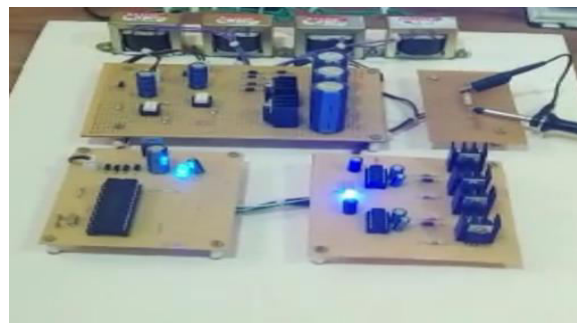

Figure 11: Hardware kit model for proposed system

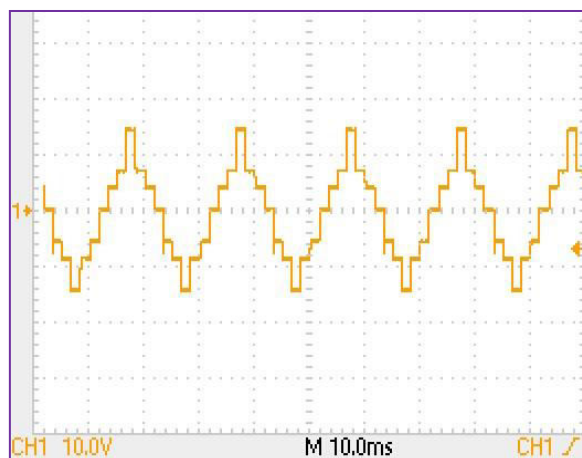

Fig.12 Output wave form 5 Level MLI



International Journal of Multidisciplinary Research in Science, Engineering and Technology (IJMRSET)

(A Monthly, Peer Reviewed, Refereed, Scholarly Indexed, Open Access Journal)

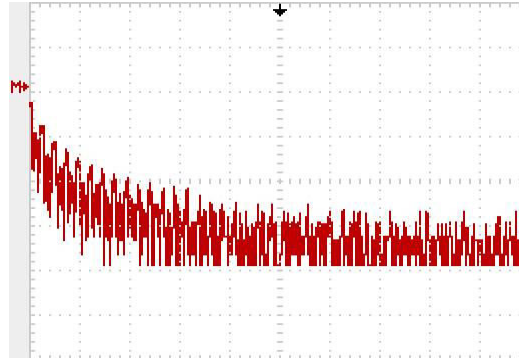

Fig.13 THD of Hardware

Hard ware 7 level Multi level inverter THD = 3.72%

VII. CONCLUSION

In this paper, THD in load voltage, Active Power and Reactive Power are measured for the two plans utilizing SIMULINK/MATLAB programming and afterward looked at for a similar dc input voltage and same RL load with and without using reversing voltage. In the two plans, THD got in load voltage may generally be decreased below 5% by the utilization of filter.

The THD is better as well as cost is less for the second plan. This intends that assuming the Solar Panels having same power rating and same attributes are associated in both the plan, the Power Quality will be better and cost is less for second plan. Dynamic Power and Reactive Power are something else for Cascaded H-Bridge Inverter as contrast with new staggered plot.

REFERENCES

- [1] Ankita Papriwall , Dr. Amita Mahor, MITIGATION OF HARMONICS IN INVERTER, IOSR Journal of Engineering (IOSRJEN) e-ISSN: 2250-3021, p-ISSN: 2278-8719, Volume 2, Issue 9 (September 2012), PP 98-105
- [2] G. Mahesh, Manivanna Kumar and S. Rama Reddy, "Simulation and Experimental Results of 7-Level Inverter System", Research Journal of Applied Sciences, Engineering and Technology, pp. 88-95, 2011
- [3] Ali, J.S.M.; Alishah, R.S.; Sandeep, N.; Hosseini, S.H.; Babaei, E.; Vijayakumar, K.; Yaragatti, U.R. A new generalized multilevel converter topology based on cascaded connection of basic units. IEEE Trans. J. Emerg. Sel. Top. Power Electron. 2018, 7, 2498–2512.
- [4]. Meza, C.; Negroni, J.J.; Biel, D.; Guinjoan, F. Energy-balance modeling and discrete control for single-phase grid-connected PV central inverters. IEEE Trans. Ind. Electron. 2008, 55, 2734–2743.
- [5]. Oikonomou, N.; Gutscher, C.; Karamanakos, P.; Kieferndorf, F.; Geyer, T. Model predictive pulse pattern control for the five-level active neutral point-clamped inverter. IEEE Trans. Ind. Appl. 2013, 46, 2583–2592. [CrossRef]
- [6]. Huang, J.; Corzine, K. Extended operation of flying capacitor multilevel inverters. IEEE Trans. Power Electron. 2006, 21, 140–147.
- [7]. Telander RL, Morgan KG, Kreulen DL, Schmalz PF, Kelly KA, et al. Human gastric tony
- [6] Mohammad Ahmad and B. H. Khan, Senior Member, IEEE, New Approaches for Harmonics Reduction in Solar Inverters, 978-1-4673-0455-9/12/\$31.00 ©2012 IEEE
- [8]. Hasan, M.; Mekhilef, S.; Ahmed, M. Three-phase hybrid multilevel inverter with less power electronic components using space vector modulation. Power Electron. IET 2014, 16, 1504–1512
- [9]. Daher, S.; Schmid, J.; Antunes, F.L. Multi level inverter topologies for stand-alone PV systems. IEEE Trans. Ind. Electron. 2008, 55, 2703–2712
- [10] ErsoyBesery, BirolArifoglu, SabriCamur, and EsraKandemirBeser Dept. of Electrical Eng., Kocaeli University, Kocaeli, Turkey, ' Design and Application of a Single Phase Multilevel Inverter Suitable for using as a Voltage Harmonic Source' Journal of Power Electronics, Vol. 10, No. 2, March 2010



INTERNATIONAL
STANDARD
SERIAL
NUMBER
INDIA



INTERNATIONAL JOURNAL OF MULTIDISCIPLINARY RESEARCH IN SCIENCE, ENGINEERING AND TECHNOLOGY

| Mobile No: +91-6381907438 | Whatsapp: +91-6381907438 | ijmrset@gmail.com |

www.ijmrset.com